

CP-M01-13E

Enhanced ANTARIS4 GPS Module with ultra high sensitivity



Features

- ✓ 16 channel ANTARIS4 positioning engine
- ✓ Ultra high sensitivity to -158 dBm
- ✓ Supports DGPS, WAAS, EGNOS and MSAS
- ✓ Support 1 USB and 2 USART ports
- ✓ Customized and configurable serial I/O architecture (using on-board EEPROM)
- ✓ Support 4 Hz position update rate capability (using on-board EEPROM)
- ✓ Support power saving modes (using on-board EEPROM)
- ✓ Ultra low power consumption 39mA
- ✓ 5 μ A backup current
- ✓ Low position/velocity drift in static mode
- ✓ Small form factor 25.4 x 25.4 mm with SMT pads (micro package)
- ✓ RoHS compliant (lead-free)

Block Diagram

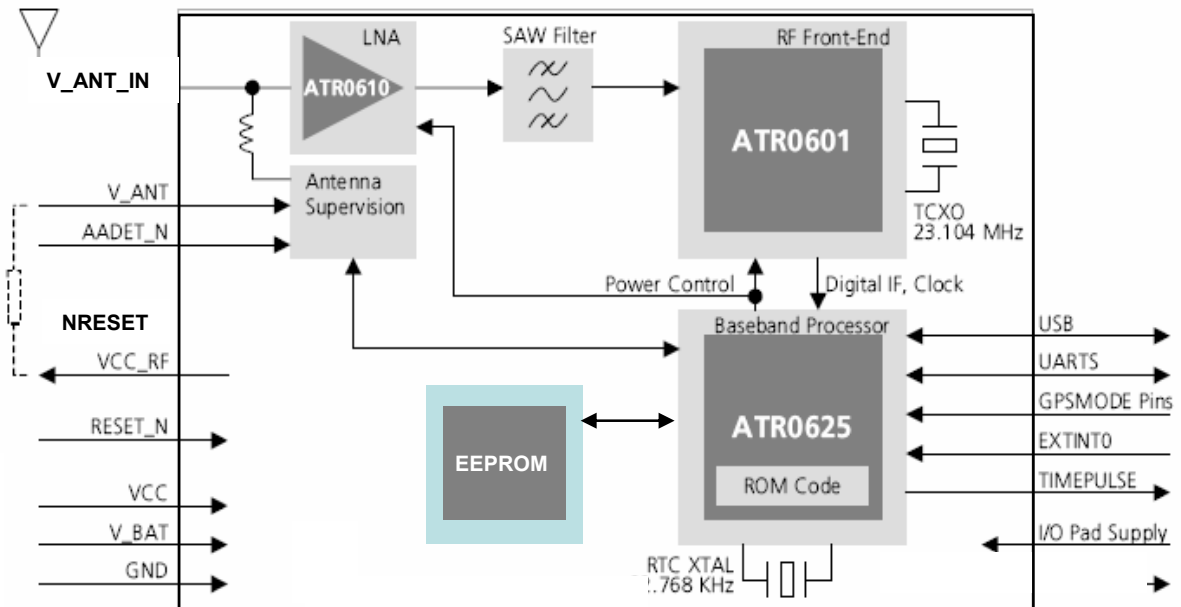

Specification

1. Electrical Characteristics

1.1 Chipset	ATR0601, ATR0625	ATMEL ANTARIS4 family (ARM7TDMI Thumb processor core embedded) with -158dBm sensitivity
1.2 General	Frequency	L1, 1575.42MHz
	Channels, C/A code	16, 1.023 MHz chip rate, 8192 time/frequency search windows
1.3 Accuracy	Position	2.5 meters CEP
	Time	50 nanosecond rms (1 PPS)
1.4 DGPS Accuracy	Position	2 meters CEP
1.5 Acquisition Rate	Reacquisition	< 1 sec, typical
	Cold start	34 sec, typical
	Warm start	33 sec, typical
	Hot start	3.5 sec, typical
1.6 Sensitivity	Tracking	-158 dBm
	Acquisition/Reacquisition	-148 dBm
	Cold start	-142 dBm
1.7 Dynamic Condition	Altitude	18,000 meters (60,000 Feet) max.
	Velocity	515 meters /sec (1000 Knots) max.
1.8 Power	Main Power	3.3 VDC
	Supply current	39 mA (80uA in power saving mode)
	Backup power	1.5 ~ 3.6V
	Backup current	5µA typical
1.9 Serial Port	Electrical interface	USART, USB
	Protocol	NMEA, UBX (ublox proprietary), RTCM Default I/O configuration 8 data bits, no parity, 1 stop bits USART1/USB: 9600 baud, output NMEA USART2: 38400 baud, output UBX Low position/velocity drift in static mode 4 Hz position update rate capability and configurable I/O (EEPROM)

2. Environmental Characteristics

2.1 Temperature	Operating range	- 40 to + 85
2.2 Dimensions	L x W x H	25.4 x 25.4 x 3.0 mm
2.3 Interface	I/O connector	30 pin SMD micro package

3. Antenna Requirement

Active Antenna	15~ 25 dB Gain recommended
----------------	----------------------------

Hardware Interface

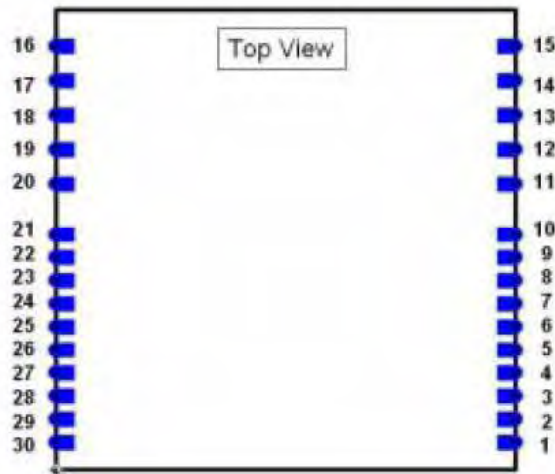

Recommended Solder Pad Layout

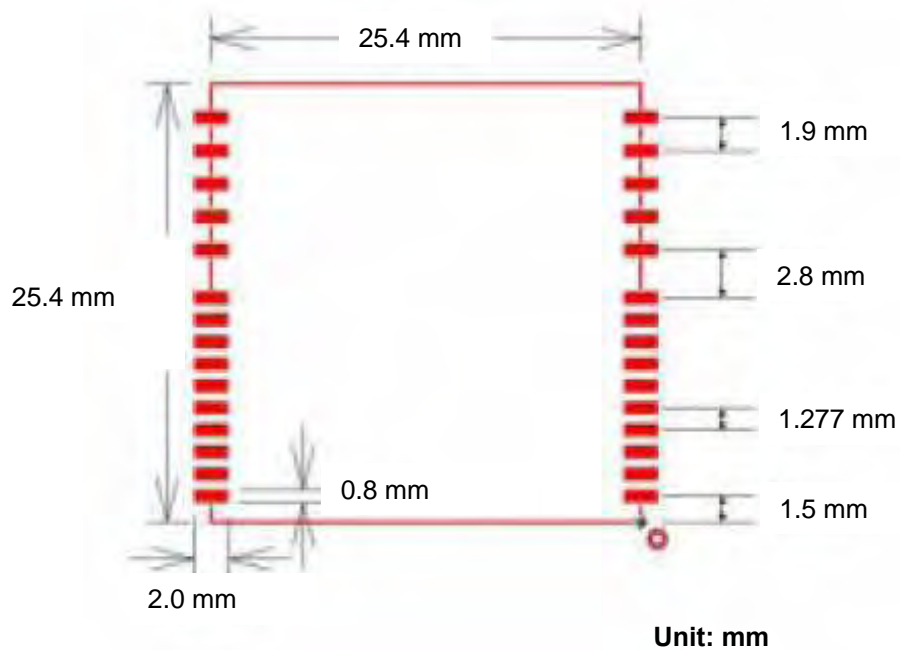

I/O Pin Definition

Pin	Name	Type	Description
1	VCC	I	DC Supply Voltage Input DC +3.3V+-5%
2	GND	G	Digital Reference Ground
3	VDD18	O	Internal regulator output, 1.8V
4	RXA	I	Serial Port A
5	TXA	O	Serial Port A
6	TXB	O	Serial Port B
7	RXB	I	Serial Port B
8	GPSMODE12	I	GPSMODE12 configuration, if not used keep floating
9	RF_ON	O	Indicates power state of RF part, 3.3V
10	GND	G	Digital Reference Ground
11	GND_A	G	Analog Reference Ground
12	GND_A	G	Analog Reference Ground
13	GND_A	G	Analog Reference Ground
14	GND_A	G	Analog Reference Ground
15	GND_A	G	Analog Reference Ground
16	GND_A	G	Analog Reference Ground
17	RF_IN	I	GPS Signal Input, 50 ohm @1.57542GHz
18	GND_A	G	Analog Reference Ground
19	V_ANT_IN	I	Active Antenna Bias Voltage
20	VCC_RF	O	Supply Active Antenna Bias Voltage, 3.3VDC typical
21	V_BAT	I	Backup Voltage Supply, 1.5VDC~ 3.6VDC
22	NRESET	I	Reset, Active Low
23	GPSMODE2	I	GPSMODE2 configuration, if not used keep floating
24	GPSMODE5	I	Serial I/O configuration (see table 1,2), if not used keep floating
25	GPSMODE6	I	Serial I/O configuration (see table 1,2), if not used keep floating
26	USB_DM	I/O	USB DM
27	USB_DP	I/O	USB DP
28	STATUS_LED	O	GPS Fix Status Indicator. When GPS is not fixed, it outputs low. When GPS is fixed, it outputs pulse. (see figure 1.)
29	PPS	O	One Pulse Per Second
30	GND	G	Digital Reference Ground

Default Serial I/O Configuration

USART1 Port Baud, Protocol	USART2 Port Baud, Protocol	USB Port Baud, Protocol	Messages
9600, Output: NMEA, Input: NMEA, UBX, RTCM	38400, Output: UBX, Input: NMEA, UBX, RTCM	9600, Output: NMEA, Input: NMEA, UBX	Medium (see Table 2)

Table 1

Messages

NMEA Protocol	GGA, GLL, GSA, GSV, RMC, VTG, ZDA
UBX Protocol	UBX-NAV, UBX-MON

Table 2

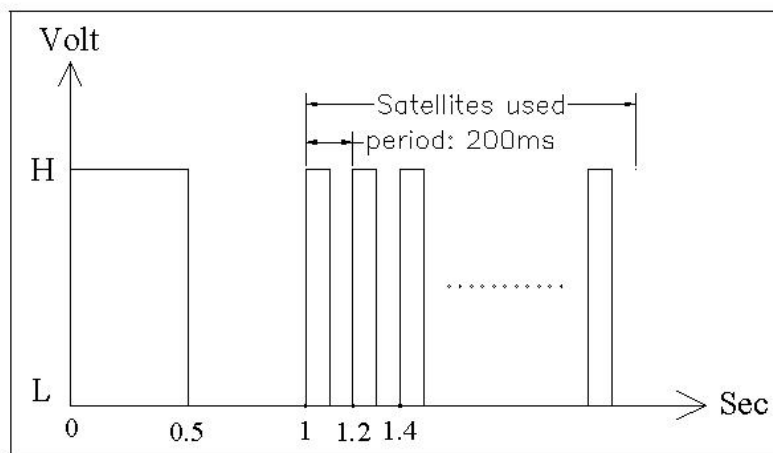

Figure 1

Customized and Configurable Serial I/O (using on-board EEPROM)

In principle, customized and configurable serial I/O can be properly set by sending proprietary input NMEA/UBX messages to SDT13E on-board EEPROM memory. The serial I/O to be configured can be 1) Baud rate, 2) Output messages, 3) Navigation mode (including static hold threshold), 4) Power mode, 5) 4 Hz position update rate, 6) and other parameters.

For detailed description, please refer to proprietary input NMEA/UBX protocol manual.

Here we present some typical examples

1. Change static hold threshold value (Item 3) to 0.5 m/s (factory: 0.9 m/s):

Send input UBX messages as follows

```
B5 62 06 1A 28 00 03 00 00 00 03 04 10 02 50
C3 00 00 18 14 05 3C 00 03 00 00 FA 00 FA 00
64 00 2C 01 32 00 00 00 00 00 00 00 00 00 00
00 9E ED
```

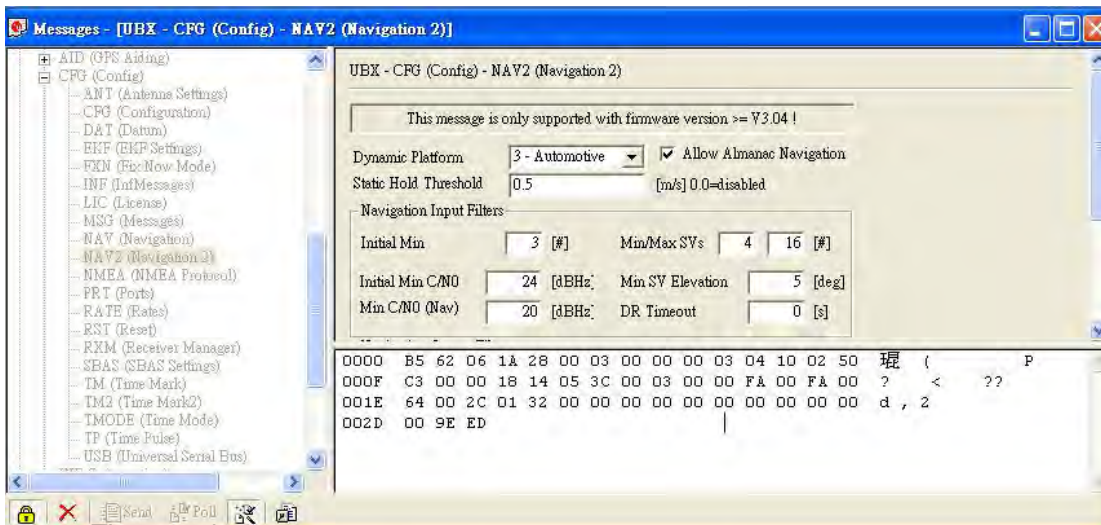

Then send

```
B5 62 06 09 0C 00 00 00 00 00 FF FF FF FF 00
00 00 00 17 75
```

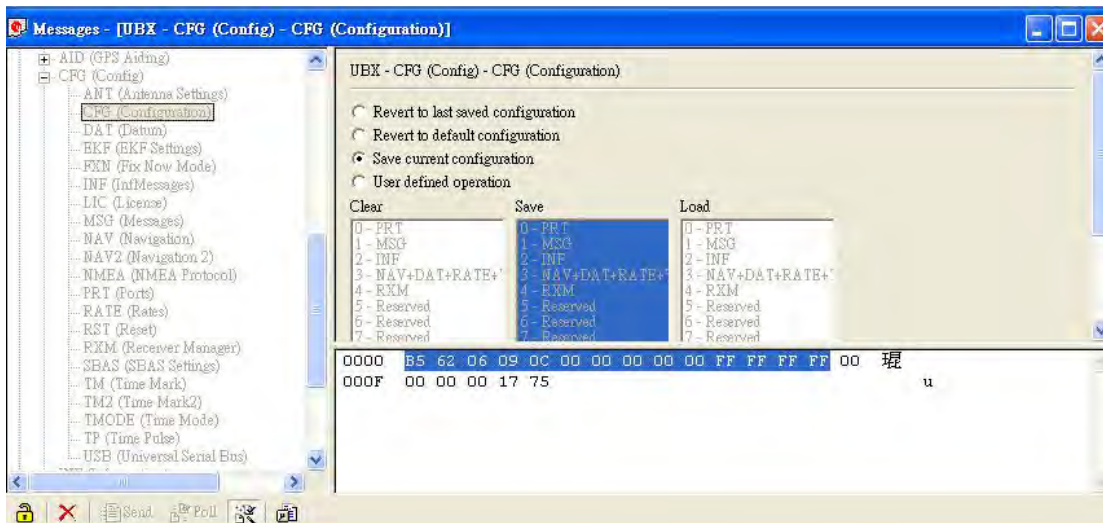

- Change position update rate (Item 5) to 4 Hz (factory: 1 Hz)
Send input UBX messages as follows
B5 62 06 08 06 00 FA 00 01 00 01 00 10 96

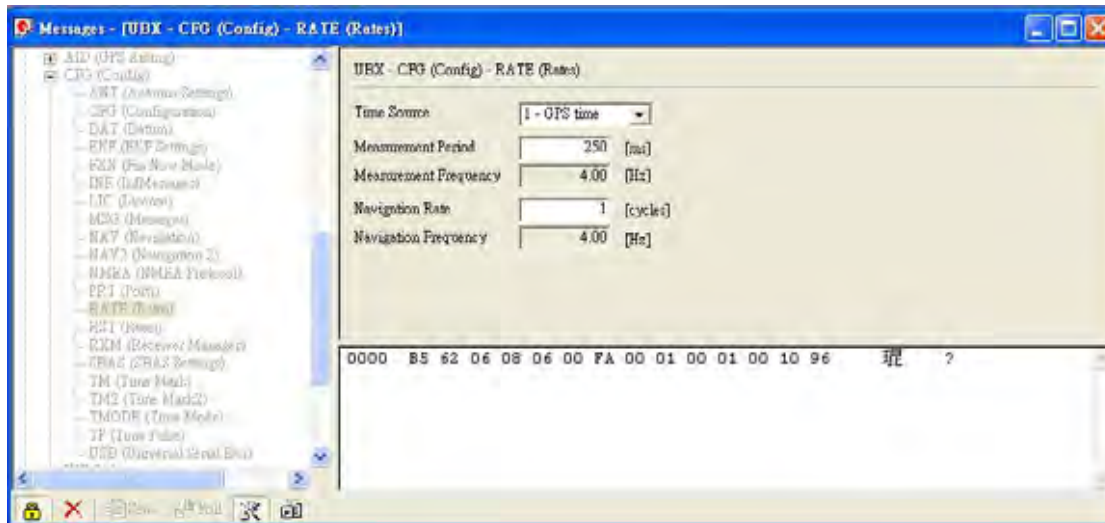

- Then send
B5 62 06 09 0C 00 00 00 00 00 00 FF FF FF FF 00
00 00 00 17 75

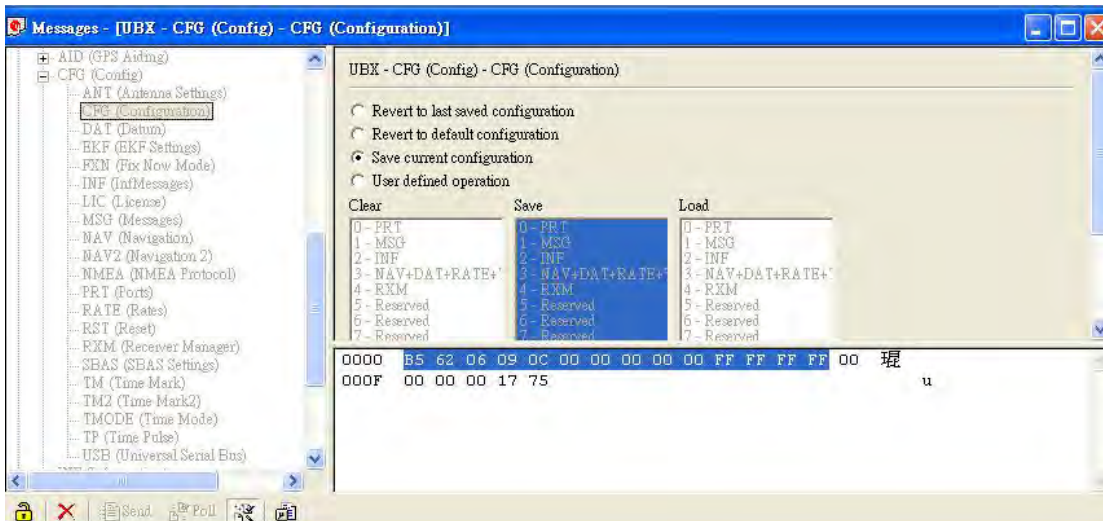

However, the more preferable business model for serial I/O configuration is:
Customized requirement highlighted by “customer”, and
Customized implementation executed by “factory”!

NMEA Output Messages

Table 3 NMEA-0183 Output Messages

NMEA Record	Description
GGA (Default)	Global positioning system fixed data
GLL (Default)	Geographic position - latitude/longitude
GSA (Default)	GNSS DOP and active satellites
GSV (Default)	GNSS satellites in view
RMC (Default)	Recommended minimum specific GNSS data
VTG (Default)	Course over ground and ground speed
ZDA (default)	Time and date

GGA--- Global Positioning System Fixed Data

Table 4 contains the values for the following example:

\$GPGGA,161229.487,3723.2475,N,12158.3416,W,1,07,1.0,9.0,M, , , ,0000*18

Table 4 GGA Data Format

Name	Example	Units	Description
Message ID	\$GPGGA		GGA protocol header
UTC Position	161229.487		hhmmss.sss
Latitude	3723.2475		ddmm.mmmm
N/S Indicator	N		N=north or S=south
Longitude	12158.3416		dddmm.mmmm
E/W Indicator	W		E=east or W=west
Position Fix Indicator	1		See Table 5
Satellites Used	07		Range 0 to 12
HDOP	1.0		Horizontal Dilution of Precision
MSL Altitude	9.0	meters	
Units	M	meters	
Geoid Separation		meters	
Units	M	meters	
Age of Diff. Corr.		second	Null fields when DGPS is not used
Diff. Ref. Station ID	0000		
Checksum	*18		
<CR> <LF>			End of message termination

Table 5 Position Fix Indicator

Value	Description
0	Fix not available or invalid
1	GPS SPS Mode, fix valid
2	Differential GPS, SPS Mode, fix valid
3	GPS PPS Mode, fix valid

GLL--- Geographic Position – Latitude/Longitude

Table 6 contains the values for the following example:

\$GPGLL,3723.2475,N,12158.3416,W,161229.487,A*2C

Table 6 GLL Data Format

Name	Example	Units	Description
Message ID	\$GPGLL		GLL protocol header
Latitude	3723.2475		ddmm.mmmm
N/S Indicator	N		N=north or S=south
Longitude	12158.3416		dddmm.mmmm
E/W Indicator	W		E=east or W=west
UTC Position	161229.487		hhmmss.sss
Status	A		A=data valid or V=data not valid
Checksum	*2C		
<CR> <LF>			End of message termination

GSA---GNSS DOP and Active Satellites

Table 7 contains the values for the following example:

\$GPGSA,A,3,07,02,26,27,09,04,15, , , , , ,1.8,1.0,1.5*33

Table 7 GSA Data Format

Name	Example	Units	Description
Message ID	\$GPGSA		GSA protocol header
Mode 1	A		See Table 9
Mode 2	3		See Table 8
Satellite Used in solution	07		Sv on Channel 1
Satellite Used in solution	02		Sv on Channel 2
Satellite Used			Sv on Channel 12
PDOP	1.8		Position Dilution of Precision
HDOP	1.0		Horizontal Dilution of Precision
VDOP	1.5		Vertical Dilution of Precision
Checksum	*33		
<CR> <LF>			End of message termination

Table 8 Mode 2

Value	Description
1	Fix not available
2	2D
3	3D

Table 9 Mode 1

Value	Description
M	Manual- forced to operate in 2D or 3D mode
A	Automatic-allowed to automatically switch 2D/3D

GSV---GNSS Satellites in View

Table 10 contains the values for the following example:

\$GPGSV,2,1,07,07,79,048,42,02,51,062,43,26,36,256,42,27,27,138,42*71

\$GPGSV,2,2,07,09,23,313,42,04,19,159,41,15,12,041,42*41

Table 10 GSV Data Format

Name	Example	Units	Description
Message ID	\$GPGSV		GSV protocol header
Number of Messages ¹	2		Range 1 to 3
Message Number ¹	1		Range 1 to 3
Satellites in View	07		
Satellite ID	07		Channel 1 (Range 1 to 32)
Elevation	79	Degrees	
Azimuth	048	Degrees	Channel 1 (Maximum 90)
SNR (C/No)	42	DBHz	Channel 1 (True, Range 0 to 359)
Satellite ID	27		Range 0 to 99, null when not tracking
Elevation	27	Degrees	Channel 4 (Range 1 to 32)
Azimuth	138	Degrees	Channel 4 (Maximum 90)
SNR (C/No)	42	DBHz	Channel 4 (True, Range 0 to 359)
Checksum	*71		Range 0 to 99, null when not tracking
<CR> <LF>			End of message termination

Note1: Depending on the number of satellites tracked multiple messages of GSV data may be required.

RMC---Recommended Minimum Specific GNSS Data

Table 11 contains the values for the following example:

\$GPRMC,161229.487,A,3723.2475,N,12158.3416,W,0.13,309.62,120598, ,*10

Table 11 RMC Data Format

Name	Example	Units	Description
Message ID	\$GPRMC		RMC protocol header
UTC Position	161229.487		hhmmss.sss
Status	A		A=data valid or V=data not valid
Latitude	3723.2475		ddmm.mmmm
N/S Indicator	N		N=north or S=south
Longitude	12158.3416		dddmm.mmmm
E/W Indicator	W		E=east or W=west
Speed Over Ground	0.13	knots	
Course Over Ground	309.62	degrees	True
Date	120598		ddmmyy
Magnetic Variation		degrees	E=east or W=west (Not shown)
Checksum	*10		
<CR> <LF>			End of message termination

VTG---Course Over Ground and Ground Speed

Table 12 contains the values for the following example:

\$GPVTG,309.62,T, ,M,0.13,N,0.2,K*6E

Table 12 VTG Data Format

Name	Example	Units	Description
Message ID	\$GPVTG		VTG protocol header
Course	309.62	degrees	Measured heading
Reference	T		True
Course		degrees	Measured heading
Reference	M		Magnetic
Speed	0.13	knots	Measured horizontal speed
Units	N		Knots
Speed	0.2	km/hr	Measured horizontal speed
Units	K		Kilometer per hour
ModeAN=no fix, A=autonomous, D=DGPS, E=DR	ModeAN=no fix, A=autonomous, D=DGPS, E=DR	ModeAN=no fix, A=autonomous, D=DGPS, E=DR	ModeAN=no fix, A=autonomous, D=DGPS, E=DR
Checksum	*6E		
<CR> <LF>			End of message termination

ZDA---Time and Date

Table 13 contains the values for the following example:

\$GPZDA,081727.00,01,02,2006,00,00*6A

Table 13 VTG Data Format

Name	Example	Units	Description
Message ID	\$GPZDA		ZDA protocol header
UTC position	081727.00	degrees	hhmmss.sss
Day	01		UTC Day, 01 to 31
Month	02		UTC Month, 01 to 12
Year	2006		UTC year, 4 digit year
Local zone hour	00		Not supported
Local zone minutes	00		Not supported
Checksum	*6A		
<CR> <LF>			End of message termination

Proprietary NMEA/UBX Messages

Please refer to detailed protocol manual.

Application Circuit

